

# PIXBOOM

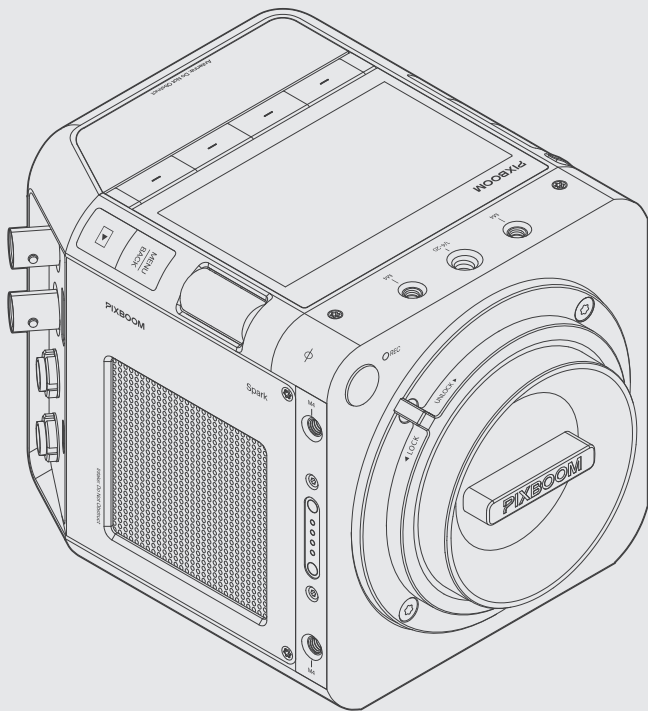

**Pixboom Spark**

**User Manual** V1.0

**PIXBOOM**

# Table of contents

---

<b>01</b>	<b>Introduction to this manual</b>		01
<b>02</b>	<b>Important safety instructions</b>		01
	2.1	General safety	01
	2.2	Electrical safety	02
	2.3	Environmental safety	02
	2.4	Operational safety	02
	2.5	Battery safety	02
	2.6	Installation and mechanical safety	03
	2.7	Additional Safety Information	03
	2.8	Intended use	04
	2.9	Explanation of signal words	04
<b>03</b>	<b>Overview</b>		
	3.1	Scope of delivery	05
	3.2	Camera	05
<b>04</b>	<b>Unpacking</b>		11
<b>05</b>	<b>Assembly</b>		
	5.1	Attaching a lens	11
	5.2	Replacing the mount adapter	12
	5.3	Inserting storage medium	13
	5.4	Attaching the Wi-Fi antenna	13
<b>06</b>	<b>Operation</b>		
	6.1	Mounting options	14
	6.2	Functions	15
	6.3	Ports and connections	17
	6.4	Settings and adjustments	25

---

<b>07</b>	<b>Use</b>	7.1	Recording	35
		7.2	Playback	36
		7.3	Export	36
<b>08</b>	<b>Cleaning and care</b>	8.1	General	37
		8.2	Camera	37
<b>09</b>	<b>Storage</b>			38
<b>10</b>	<b>Troubleshooting</b>			38
<b>11</b>	<b>Technical data</b>	11.1	Camera	40
		11.2	AC Power Adapter	43
<b>12</b>	<b>Legal</b>	12.1	United States of America	44
		12.2	European Union	45
		12.3	Australian	46
		12.4	General	47
		12.5	EU Packaging and Packaging Waste Regulation (PPWR) Compliance	49
<b>13</b>	<b>Disposal</b>	13.1	European Union	50
<b>14</b>	<b>Warranty</b>	14.1	Warranty coverage	51
		14.2	Warranty conditions	51
		14.3	Exclusions	51
		14.4	Limitation of liability	51
<b>15</b>	<b>EU declaration of conformity</b>			52
<b>16</b>	<b>UK declaration of conformity</b>			52

# 1. Introduction to this manual

Thank you for purchasing the equipment.

Read, follow and understand this manual to use the equipment safely and efficiently. Ignoring these instructions may result in serious injury or damage.

Keep this manual for future reference. If this equipment is passed to a third party, then this manual must be included.

## NOTICE!

- The use, specifications and constructions outlined in this manual were accurate at the time of publication. There is a possibility of changes being made to these, specifications and constructions without prior notice or obligations due to continuous improvements.
- For the latest manual, refer to the Pixboom website [[www.pixboom.com/downloads](http://www.pixboom.com/downloads)].

## 2. Important safety instructions

This manual provides important information regarding assembly, use and maintenance. Read this manual carefully before using the equipment to maintain safe and proper use.

### CAUTION!

Failure to follow these instructions may result in serious injury, property damage or voiding of the warranty.

### 2.1 General safety

- Only use the equipment for its intended purpose.
- Keep the equipment away from children and pets.
- Do not attempt to open, modify, disassemble or repair the equipment yourself.
- Do not operate the camera in rain or under high-humidity conditions unless adequate protection is in place. If the camera or accessories come into contact with moisture, immediately disconnect the power source.
- Clean the camera and accessories using only a dry, soft cloth. Do not expose the unit to moisture.
- Do not rinse, immerse, or apply liquids directly. Avoid using soaps, detergents, ammonia-based or alkaline cleaners, abrasives, or chemical solvents, as they may damage the lens and internal components.

## 2.2 Electrical safety

- Use only power adapters and cables recommended and approved by the manufacturer.
- This equipment is not waterproof. Avoid exposing the equipment to water, moisture or high humidity. Exposure to water or humidity may result in permanent damage to the unit, electric shock, or serious personal injury.
- Do not use the power adapter if the power cord or plug is damaged.
- Do not operate the camera in rain or under high-humidity conditions unless adequate protection is in place. If the camera or accessories come into contact with moisture, immediately disconnect the power source.
- Disconnect the equipment from the power source before cleaning or maintenance.

## 2.3 Environmental safety

- Avoid placing the equipment near heat sources or in direct sunlight. Please store the camera in a protected, level, and well-ventilated location.
- Use the equipment in a well-ventilated area to prevent overheating. Never cover ventilation openings.
- Keep the equipment away from flammable materials.
- Recommended operating and storage conditions are as follows:
  - Operating Temperature: 32°F to 104°F (0°C to 40°C)
  - Relative Humidity: 0% to 85%, non-condensing
  - Storage Temperature: -4°F to 140°F (-25°C to 60°C)

## 2.4 Operational safety

- This equipment is a fragile, precision instrument. Handle it with care at all times. Dropping, impact or improper handling may result in damage and malfunction.
- Do not use the equipment in extreme temperatures or dusty environments.
- Follow all instructions for assembly and setup to maintain proper use.

## 2.5 Battery safety

- Do not disassemble, puncture, crush or modify batteries.
- Do not expose batteries to excessive heat such as sunlight, fire or similar conditions.
- Do not short-circuit the battery terminals.
- Do not use damaged or leaking batteries. Place damaged or leaking batteries in a non-flammable container, avoiding contact with skin and contact an authorized service center or local battery recycling facility. If battery fluid comes into contact with skin or eyes, rinse immediately with plenty of clean water and seek medical attention.
- Disconnect the battery before cleaning and servicing.
- Only use batteries recommended by the manufacturer. Incorrect batteries may cause an explosion or fire.

- There is a risk of explosion if the battery is replaced with an incorrect type. Keep both new and used batteries out of reach of children.
- Do not ingest the battery. Chemical burn hazard. If the battery compartment does not close securely, stop using the product and keep it out of reach of children.
- If you suspect that batteries have been swallowed or inserted into any part of the body, seek immediate medical attention.
- This equipment is intended for use by instructed personnel only and is not intended for use by children.

## 2.6 Installation and mechanical safety

- Never use damaged equipment or equipment that has been dropped! In such cases, remove the battery and the power source from the equipment. Contact customer service to have the equipment checked or repaired.
- To avoid damaging the cord do not squeeze, bend or drag it over sharp edges.
- Never use accessories that are not recommended in this manual. They could pose a safety risk to the user and might damage the equipment. Only use original parts and accessories.
- Remove all accessories or attachments after use.
- Do not insert any objects into the housing of the equipment.
- Always install the camera on a stable support system capable of bearing the full weight of the camera and all attached accessories. Secure the camera using the 1/4-20 and/or 3/8-16 mounting points located on the bottom of the unit, and confirm that all mounting screws are firmly tightened.
- Improper mounting or placement on an unstable surface may cause the camera to fall, resulting in injury or equipment damage.
- Avoid subjecting the camera to excessive vibration, shock, or impact.
- Strong mechanical shocks may damage internal components and affect the optical alignment of the lens system.

## 2.7 Additional safety information

- Do not block any ventilation openings or restrict airflow from the cooling fan. Maintain a minimum clearance of 1 inch (2.5 cm) between the equipment ventilation openings and surrounding surfaces. Ensure that objects do not obstruct the air intake or exhaust ports. Insufficient ventilation may cause overheating, reduced performance, or permanent damage to the equipment.
- Do not point the camera directly at intense light sources such as the sun or laser beams, as this may cause permanent damage to the image sensor or optical components. Such damage is not covered by the manufacturer's warranty.
- Operation of nearby devices emitting radio or other communication signals may cause interference or malfunction, and may affect audio or video quality.

## 2.8 Intended use

### **CAUTION!**

---

Do not use the equipment for any purpose other than its intended use, as described in this manual. Other use is considered unauthorized.

- The equipment is specifically designed for:
  - Professional cinematography and video recording.
  - Creative applications in film, advertising and visualization projects.
  - Use within controlled environments by trained users.
- This equipment is intended for use in professional cinema and content production workflows.
- The equipment is intended to be used in dry environments only. Do not expose to rain or water.

## 2.9 Explanation of signal words

The following signal words are used in this manual, on the equipment and/or on the packaging.

### **DANGER!**

---

This signal word is used to indicate a hazardous situation which, if not avoided, will result in death or serious injury.

### **WARNING!**

---

This signal word is used to indicate a hazardous situation which, if not avoided, could result in death or serious injury.

### **CAUTION!**

---

This signal word is used to indicate a hazardous situation which, if not avoided, could result in minor or moderate injury.

### **CAUTION!**

---

This signal word is used to indicate a potentially hazardous situation which, if not avoided, could result in equipment or property damage.

### **NOTICE!**

---

This signal word is used to indicate additional useful tips and information.

## 3. Overview

### 3.1 Scope of delivery

- Pixboom Spark Camera
- Pixboom Pro Card - 2.5TB
- Pixboom Mount Adapter : E/EF/PL Adapter
- 20Gbps High Speed Type-C Cable
- AC Power Adapter
- Mount Adapter Shim Kit

### 3.2 Camera

#### 3.2.1 Front, back and bottom view

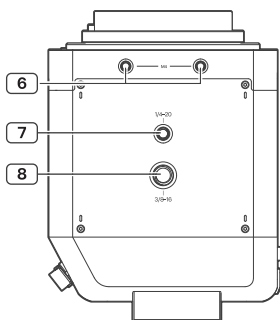
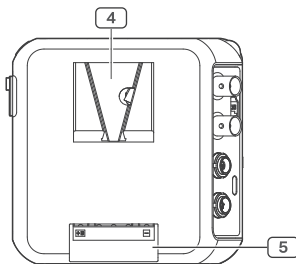
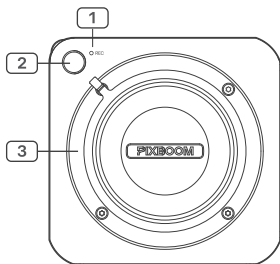

- 1 REC indicator
- 2 Record button
- 3 Mount adapter
- 4 V-Lock battery mount
- 5 Battery attachment terminal
- 6 M4 mounting point
- 7 1/4-20 mounting point
- 8 3/8-16 mounting point

### 3.2.2 Top view

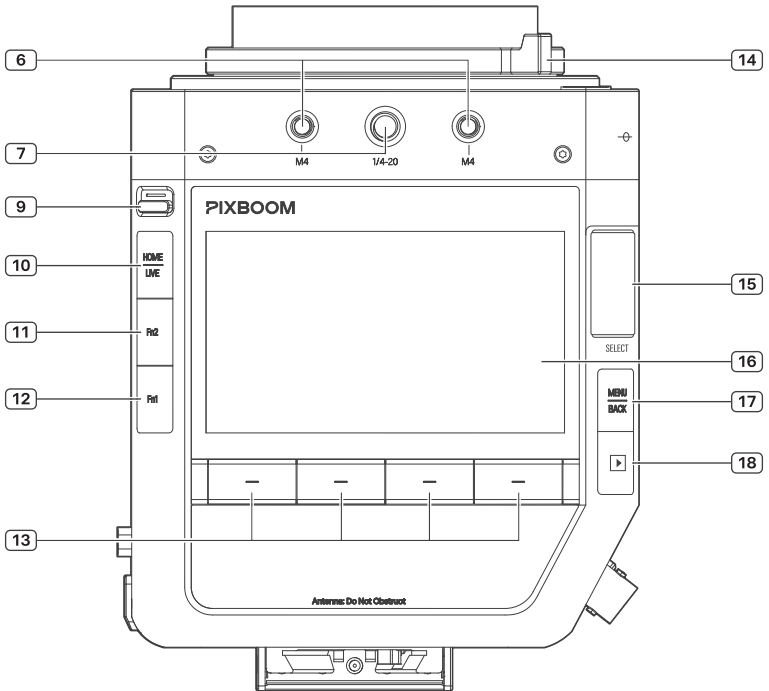

6 M4 mounting point

7 1/4-20 mounting point

9 Touch screen lock

10 HOME/LIVE button

11 Fn2 button

12 Fn1 button

13 Screen buttons

14 Lens locking handle

15 SELECT wheel

16 Touch screen

17 MENU/BACK button

18 Playback button

### 3.2.3 Left view

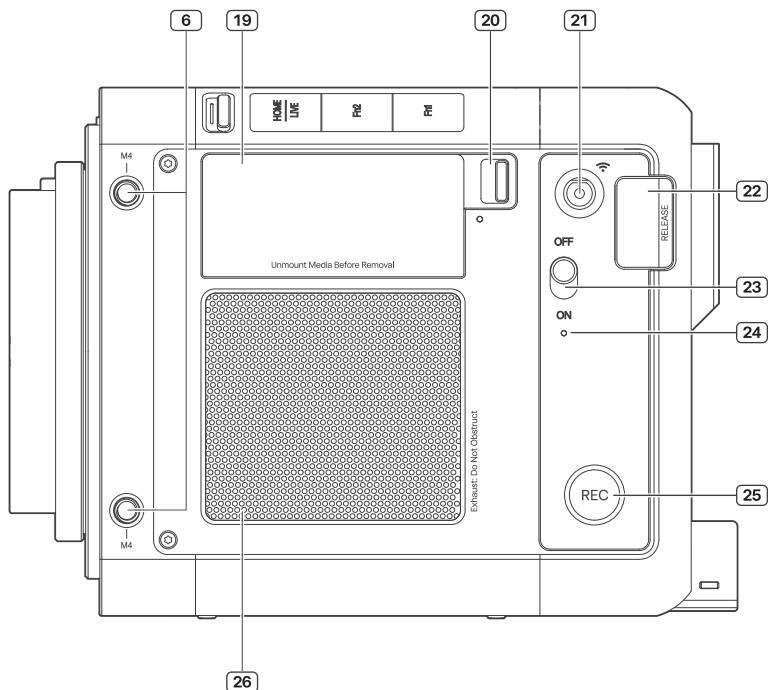

- 19 Media compartment
- 20 MEDIA release (Pixboom Pro Card)
- 21 External Wi-Fi antenna port
- 22 RELEASE button (battery)

- 23 ON/OFF switch
- 24 Power status indicator
- 25 Side REC button
- 26 Ventilation opening

### 3.2.4 Right view

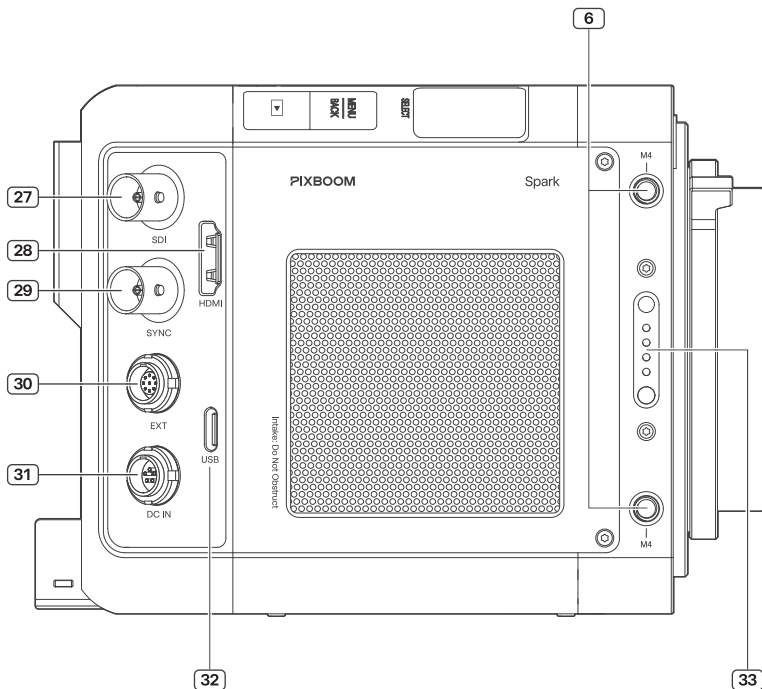

- 27 SDI port
- 28 HDMI port
- 29 SYNC port
- 30 9-pin EXT port

- 31 5-pin DC IN port
- 32 USB Type-C port
- 33 UART port with magnet

### 3.2.5 Accessories

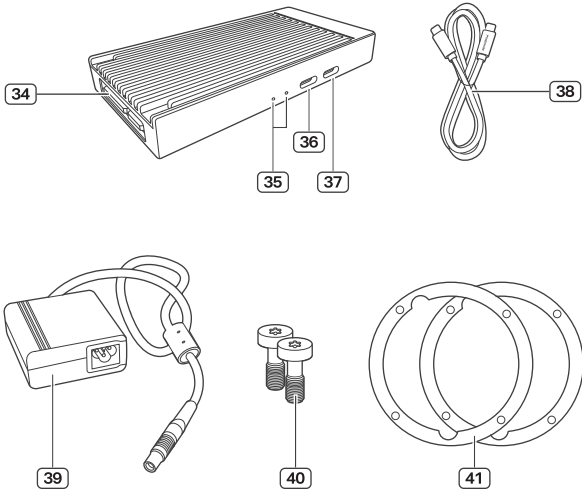

- 34** Pixboom Pro Card - 2.5 TB
- 35** Pixboom Pro Card status LED
- 36** USB Type-C data port  
(USB 3.2 Gen 2 × 2 up to 20 Gbps)
- 37** USB Type-C power port  
(auxiliary power supply)

- 38** USB Type-C cable  
(High Speed cable up to 20 Gbps)
- 39** AC Power Adapter with equipment  
connector
- 40** Replacement Screws (× 2)
- 41** Adapter Shim Kit (6 pcs)

### 3.2.6 Mount Adapters



42

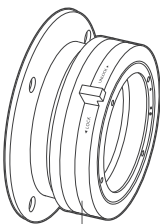

43

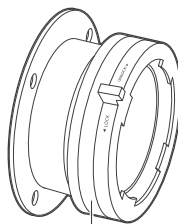

44

42 E Mount Adapter

43 EF Mount Adapter

44 PL Mount Adapter

#### NOTICE!

Pixboom Spark supports interchangeable mount adapters for different lens systems. Each standard package includes one mount adapter, selected from E, EF, or PL mount options. The included mount adapter varies depending on your selected configuration. Additional mount adapters are available separately.

## 4. Unpacking

### **⚠ WARNING! Risk of suffocation!**

Keep packaging materials away from children and pets to avoid suffocation risks.

- Carefully open the box and remove all packing materials. Dispose of and recycle the packing materials in accordance with local regulations.
- Carefully inspect the packaging for any visible signs of damage, such as dents, punctures or tears. Promptly contact our customer service regarding any significant issues. Make sure that the delivery content is complete and undamaged before using the equipment.
- Thoroughly inspect the equipment for any visible damages, scratches or defects. Verify that all parts and accessories are present and report any damages or missing components to our customer service.

## 5. Assembly

### 5.1 Attaching a lens

#### **NOTICE!**

The procedure below applies to all compatible lenses. The lens shown is for demonstration purposes only and is not included in the standard package.

1. Switch the equipment off.
2. Unlock the mount adapter (3) and remove the cover (Fig.1).
3. Remove the rear lens cover of the camera lens.
4. Inspect the mount adapter and rear lens element for dust or debris and clean if necessary using approved tools.
5. Align the camera lens with the mounting marks on the mount adapter (3).
6. Lock the mount adapter (3) to secure the camera lens in place (Fig.2).
7. Gently try to rotate the lens to confirm it is securely locked in place.

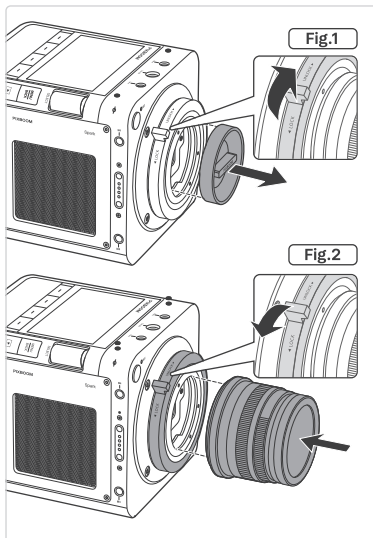

## 5.2 Replacing the mount adapter

### NOTICE!

The procedure below for replacing the interchangeable mount adapter (3) is the same for changing to other types of compatible interchangeable mount adapters.

1. Switch the equipment off and remove any connected camera lens.
2. Use a 3.0 mm hex key to carefully loosen all 4 screws on the mount adapter (3) by turning them counterclockwise (Fig.3).
3. Remove the mount adapter (3) and the adapter shim (41) (Fig.4).
4. Attach one of the other mount adapters (3) together with the adapter shim (41) (Fig.5).
5. Tighten the screws by turning them clockwise using a 3.0 mm hex key.

### NOTICE!

Tighten the screw evenly. Do not overtighten to avoid damaging the mount.

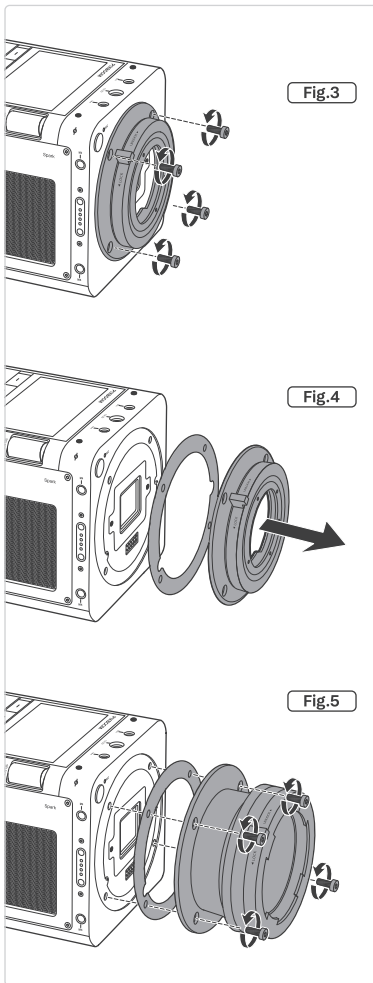

### 5.3 Inserting storage medium

1. Slide the MEDIA release (20) sideways to open the media compartment (19).
2. Insert the Pixboom Pro card - 2.5 TB or another compatible storage medium until it clicks in place. Refer to the Pixboom website or latest compatibility list for approved storage media types and capacities.
3. Close the media compartment (19) and make sure it is securely locked (Fig.6).

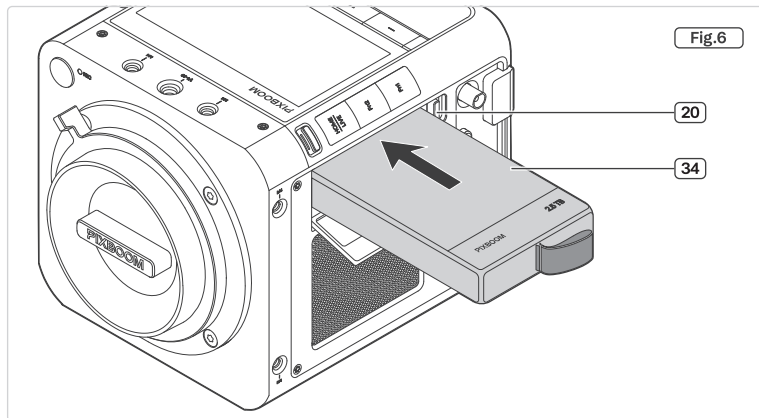

### 5.4 Attaching the Wi-Fi antenna

1. Align the antenna with the external Wi-Fi antenna port (21).
2. Attach the antenna to external Wi-Fi antenna port (21) by turning it clockwise.

## 6. Operation

### **⚠ WARNING! Risk of damage or injury!**

- Never use the equipment if the power adapter, connectors or housing is damaged. Always inspect the equipment and all connections before switching the equipment on.
- Avoid exposing the equipment to excessive heat, moisture or dust to prevent equipment damage.
- Do not point the camera lens directly at high-intensity light sources, as this may cause severe and potentially permanent damage to the image sensor or other internal components, especially when imaging the sun, lasers, or other high intensity light sources intensity light sources.
- Make sure that the equipment is securely assembled before operation to prevent accidental falls or damage.
- Keep the operating area clean and free from liquids, flammable materials or obstacles that may interfere with safe operation.

### 6.1 Mounting options

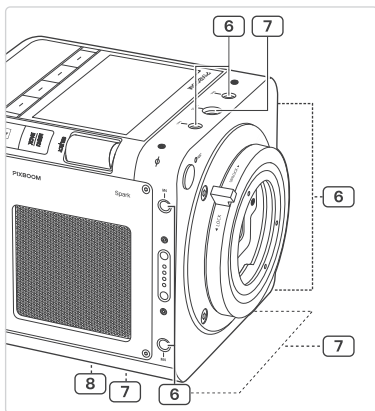

**6** M4

Mounting point for accessories.

**7** 1/4-20

Mounting point for standard tripods.

**8** 3/8-16

Mounting point for heavy rigs.

### **NOTICE!**

Use mounting hardware rated for the total system weight and follow the tripod/rig manufacturer's load specifications.

## 6.2 Functions

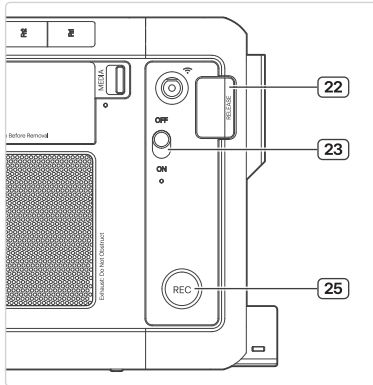

### 22 RELEASE button

Press to release the battery from the battery slot.

### 23 ON/OFF switch

Turns the camera on or off. The Power status indicator shows the current status.

### 25 Side REC button

Secondary record control when rigged or handheld. Press to start/stop recording.

### 9 Touchscreen lock switch

Toggle to enable/disable the screen lock. When the lock is engaged, a red line becomes visible.

### 10 HOME/LIVE button

Toggles between the Home menu and the Live View screen. Useful for quick access to settings during shooting.

### 11 12 Fn1 and Fn2 buttons

Customizable function buttons. They can be assigned to common actions such as:

- REC start/stop
- ISO adjustment
- White balance
- Focus assist tools

Both buttons behave identically and can be configured independently.

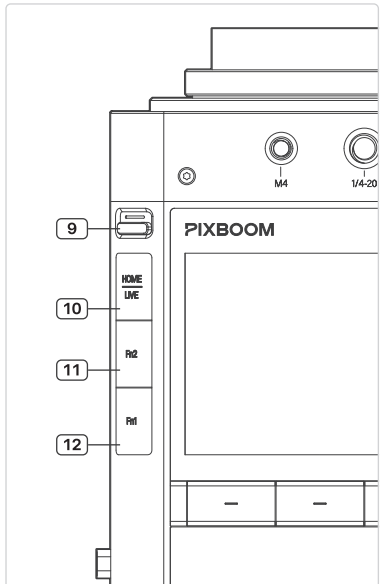

## 2 Record button

Single press to start/stop recording.  
Supports half press for assignable actions,  
pre-record, focus.

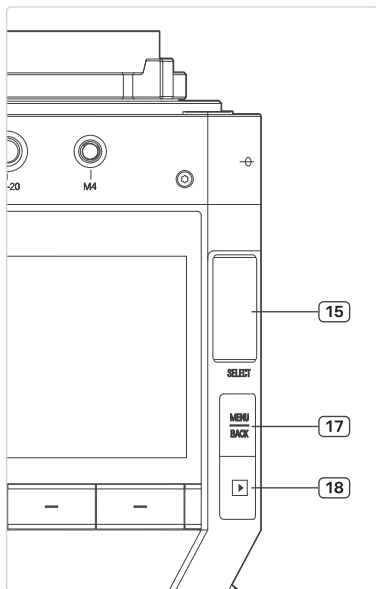
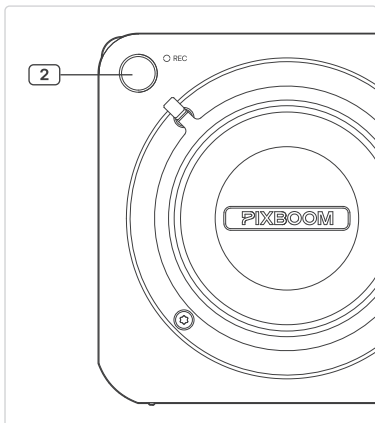

## 15 SELECT wheel

Scroll through menus by rotating. Press to confirm selections. Acts as a combined navigation and selection wheel.

## 17 MENU/BACK button

Opens the main menu. Press again to go back one level or cancel the current action.

## 18 Playback button

Switches to playback mode to review recorded clips directly on the camera touchscreen.

## 6.3 Ports and connections

### 27 SDI port

Use to transmit high-quality digital video and audio signals to external monitors, recorders or broadcast equipment.

### 28 HDMI port

Use to transmit high definition audio and video signals from the equipment to external monitors, recorders or other HDMI compatible devices.

### 29 SYNC port

Use to synchronize equipment with external signals to precisely align the frame timing with other equipment or recording devices for multi-camera setups.

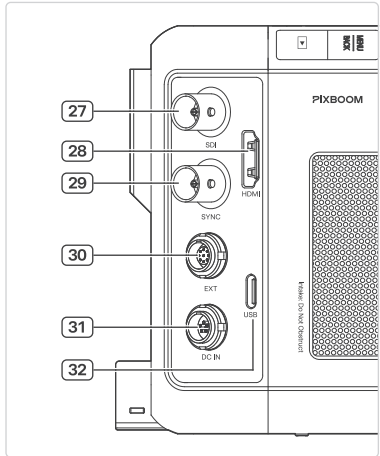

### 30 9-pin EXT port

Use to connect external accessories, control devices or triggers to expand equipment functionality and integrate with additional equipment.

### 31 5-pin DC IN port

Use to connect external batteries or power sources.

### 32 USB Type-C port

For data transfer and power input.

### 33 UART port

Use to connect UART accessories.

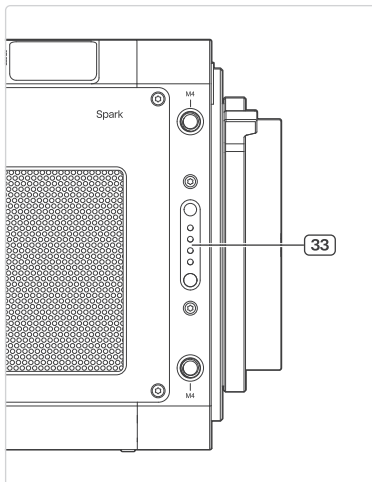

### 6.3.1 HDMI

The HDMI (High Definition Multimedia Interface) port (28) is the equipment's standard video output interface, used to connect the equipment to external monitors or recorders. It delivers a live feed of the captured image in real time, supporting high-resolution formats (such as Full HD or 4K) depending on the equipment's settings.

1. Use a certified HDMI 2.0 or higher cable for 4K output.
2. Plug one end of the HDMI cable into the HDMI port (28).
3. Connect the other end of the HDMI cable to a monitor (for live view) or an external recorder.
4. Go to MENU → Monitoring → HDMI SET.
5. Set HDMI output resolution (for example 1080p, 4K).
6. Match the frame rate to your project (for example 24, 30, 60 FPS).
7. Choose whether to display overlays (equipment info) or a clean feed.
8. Confirm the monitor/recorder detects the signal.
9. Adjust input settings on the external device if needed.
10. Verify image quality and stability before recording.

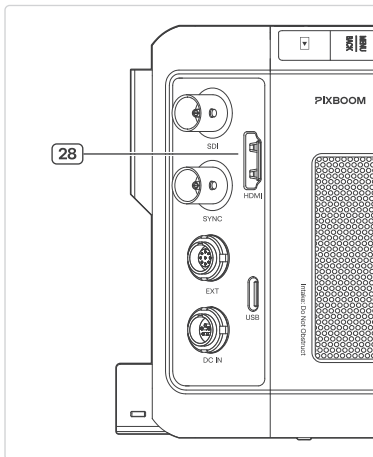

#### NOTICE!

- Make sure that the equipment is powered by a stable DC source or compatible battery.
- Avoid switching power sources while HDMI transmission is active.
- Changing HDMI output settings during recording may interrupt the output signal. Adjust settings before recording when possible.

### 6.3.2 USB 2.0 Type-C

The USB Type-C port (32) is a multi-purpose connector on the equipment that supports firmware updates, control signal transmission and power output.

1. Plug the Type-C cable into the USB Type-C port (32).
2. Connect the other end of the USB Type-C cable to a computer or docking station.
3. Use the USB Type-C port (32) for firmware updates provided by Pixboom.
4. Verify file integrity after copying and before deleting the original files.

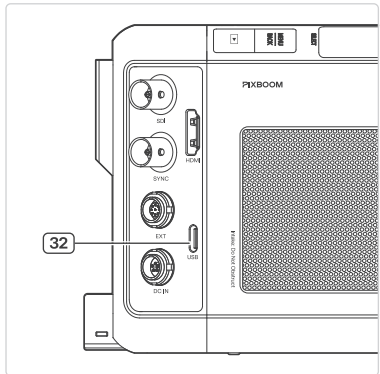

#### NOTICE!

Confirm the external device recognizes power from the camera when using the USB Type-C port for peripheral power output.

### 6.3.3 SDI

The SDI port (27) is a professional video output interface designed for high-quality, low-latency signal transmission. Using standard BNC connectors and 75-ohm coaxial cables, it delivers stable video feeds over long distances, making it ideal for broadcast, live monitoring and external recording. Unlike HDMI, SDI is more rugged and supports extended cable runs, ensuring reliable integration into professional production workflows.

#### NOTICE!

Use a professional SDI cable (75-ohm coaxial, BNC connectors).

1. Plug one side of the SDI cable into the SDI port (27).
2. Connect the other side of the SDI cable to a monitor, video mixer or external recorder with an SDI input.
3. Go to MENU → Monitoring → SDI → SET.
4. Select desired resolution (HD, 4K).
5. Match the frame rate with your project (24, 30, 60 FPS, etc.).
6. Choose whether to output a clean feed or include overlays.
7. Confirm the monitor/recorder detects the SDI signal.
8. Check the image quality and stability. If no signal is detected, check the cable connection, review the menu settings and confirm the correct input source on the output device.

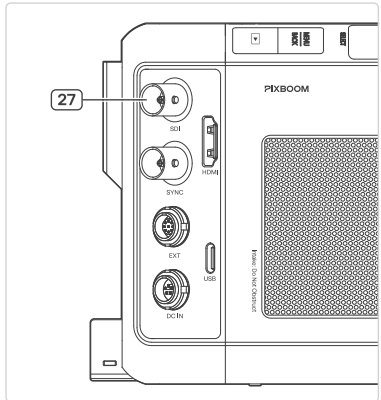

#### NOTICE!

- Make sure that the equipment is powered by a stable DC source or professional battery.
- Power the receiving device on before enabling SDI output.

#### Protecting the SDI Output

The SDI output may be damaged by improper cable connection or disconnection, especially when an accessory is connected through a BNC cable and powered by an unshielded power cable.

To help protect the Pixboom SDI output:

- Connect the power cable first, then connect the BNC cable.
- Disconnect the BNC cable first, then disconnect the power cable.
- Use shielded power cables and high-quality, undamaged BNC cables.
- An SDI isolator may be used for additional protection, but it may reduce signal quality and/or maximum cable length.
- D-Tap/P-Tap cables are not shielded, so the correct connection sequence must always be followed.

### 6.3.4 SYNC

The SYNC port (29) is designed to receive an external synchronization signal from a master clock, trigger device or sync generator. This ensures the equipment's recording is perfectly aligned with other equipment in multi-equipment setups or broadcast environments. By locking the equipment's timing to an external source, SYNC prevents frame drift, maintains consistent frame rates and guarantees precise coordination during high-speed or long-duration shoots.

#### NOTICE!

Use a dedicated sync cable compatible with the SYNC port (29) (often BNC or 3.5mm depending on model).

1. Plug one side of the sync cable into the SYNC port (29) on the equipment.
2. Connect the other end to the master clock, trigger device or external sync generator.
3. Go to Settings > Sync > Input Mode.
4. Select SYNC as the active source.
5. Match the frame rate and timing with the external device.
6. Verify that the camera detects the sync signal (indicator light or menu confirmation). If no signal is detected, reconnect the cable, check the sync source output and confirm the menu settings.

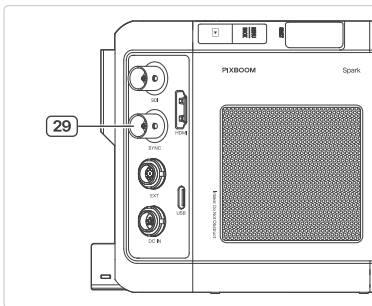

#### NOTICE!

- Confirm the equipment is powered by a stable DC source or professional battery.
- Power on the sync source before enabling sync on the equipment.

### 6.3.5 EXT (External port)

The EXT port (30) is a versatile external interface designed to connect the equipment with accessories, remote controls or synchronization devices. It allows users to trigger recording, integrate timecode or coordinate with external systems, making it especially useful in multi-equipment setups and advanced production workflows.

#### NOTICE!

The equipment can be operated remotely using remote controls or synchronization devices. Future updates will allow operation through the official applications.

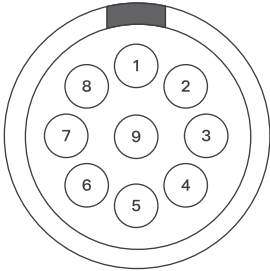

Pin	Name	Description
1	OUT_0	General purpose out 0
2	TC_OUT	Timecode out
3	GEN_OUT	Genlock out
4	UART_TX	Serial port transmit
5	UART_RX	Serial port receive
6	IN_0	General purpose in
7	TC_IN	Timecode in
8	OUT_1	General purpose out 1
9	GND	Isolation signal ground

All GPIO ports use digital isolators and support external pull-up resistors (1 kΩ to 10 kΩ) at either 3.3 V or 5 V. When no pull-up resistor is applied, the default configuration is 3.3 V for both input and output. UART can operate at either 3.3 V or 5 V logic levels. The default baud rate is 115200.

1. Connect one end of a suitable external cable to the EXT port (30).
2. Connect the other end of the external cable to the external accessory or control device (e.g., remote trigger, time code generator or external controller).
3. Go to Settings EXT Control.
4. Select the appropriate mode (remote trigger, accessory sync or external control).
5. Match timing or control parameters with the external device.
6. Verify that the equipment responds to the external device. If no signal is detected, reconnect the cable, check the external device and confirm menu settings.

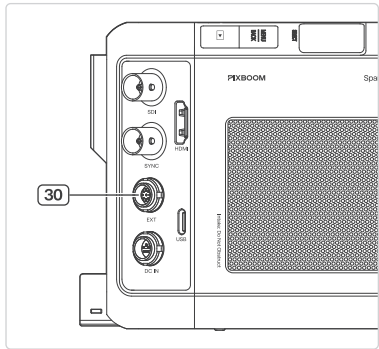

#### NOTICE!

- Confirm the equipment is powered by a stable DC source or professional battery.
- Power on the external device before enabling EXT functions.

### 6.3.6 DC IN port

The DC IN port (31) is the dedicated battery interface for powering the camera. It connects to professional battery systems (such as V-mount ) or compatible DC sources, ensuring stable and reliable operation during recording. This port is designed to deliver consistent power for high-performance recording, especially in demanding environments where uninterrupted operation is critical.

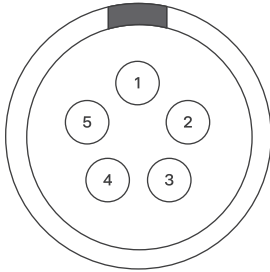

Pin	Name	Description
1	+V	Power input
2	+V	Power input
3	+V	Power input
4	GND	Power return (camera ground)
5	GND	Power return (camera ground)

Power input range:

- Accepts a voltage range of 15–24 V ( $\pm 10\%$ ).
  - When both the DC IN port (31) and a battery are connected, the equipment will prioritize DC IN port (31) automatically.
1. Plug the adapter cable into DC IN port (31) on the equipment.
  2. Connect the external power source.
  3. Switch the external battery on. Confirm the equipment powers up and displays battery status.
  4. Alternatively, use a V-Lock battery.

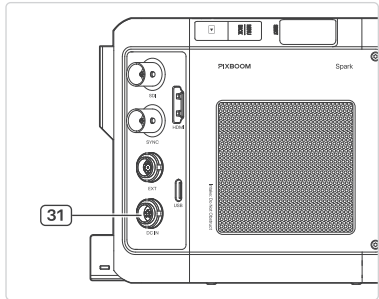

#### NOTICE!

The equipment will work without a V-Lock battery, as long as another power source is connected.

### 6.3.7 UART port

UART port with magnet (33) refers to a Universal Asynchronous Receiver-Transmitter (UART) interface that is paired with a magnetic connector.

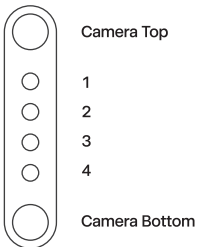

Pin	Name	Description
1	UART_RX	Serial port receive
2	UART_TX	Serial port transmit
3	GND	Signal ground
4	VCC_5V	5V (max. 1A) output

Accessory expansion pins with magnets:

- Provide UART communication with accessories for equipment control.
- Operate at a 5 V logic level.
- Supply a 5 V output (1A max) with built-in power protection.
- The protection circuit will immediately cut off the 5 V output in case of a short circuit.

## 6.4 Settings and adjustments

### 6.4.1 User adjustments

Please note that the GUI is subject to change with firmware updates. The version shown here is preliminary.

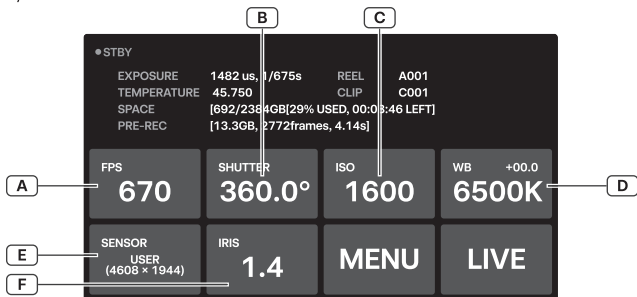

**A** **FPS**  
16 to fps max. value\*

Sets how many frames are recorded per second; higher FPS creates smoother slow motion playback but increases data and light requirements.

\*Value depends on the resolution.

**D** **WB**  
2500K to 8000K

Adjusts color temperature in Kelvin (K) to ensure whites appear neutral under different lighting conditions.

**B** **SHUTTER**  
0.1 to 360.0°

Controls how long each frame is exposed; faster shutter speeds reduce motion blur, while slower speeds increase brightness and blur.

**E** **SENSOR**  
4608×3072 to 256×32

Selects the sensor mode or scan area, allowing users to choose from default or custom resolutions. This affects the resolution, crop factor and frame rates.

**C** **ISO**  
400 to 1600

Defines the equipment's sensitivity reference; higher EI brightens the image but increases noise, lower EI reduces noise but needs more light.

**F** **IRIS**  
min. to max. lens value\*

Controls the lens aperture; wider openings increase brightness and reduce depth of field, smaller openings do the opposite.

\*Please refer to the specific lens specifications for accurate information.

## 6.4.2 Information

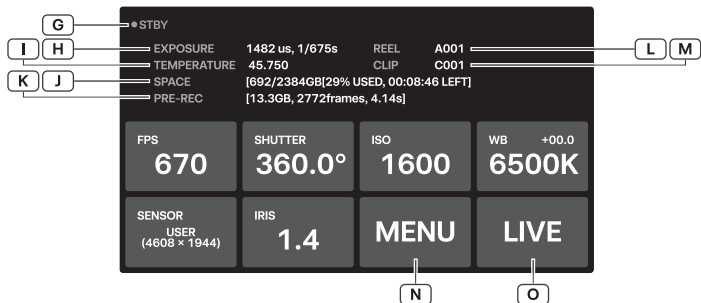

### **G** Equipment status

STBY - equipment in standby mode  
REC - recording in progress

### **H** EXPOSURE

Shows the set SHUTTER in microseconds (1482  $\mu$ s) and in fractional seconds (1/675 s).

### **I** TEMPERATURE

Shows the current internal temperature of the equipment.

### **J** SPACE

Shows the used and total space in GB as well as a % and remaining time.

### **K** PRE-REC

Displays the available pre-recording buffer capacity, the total number of buffered frames, and the pre-recording duration based on the current resolution and frame rate settings.

### **L** REEL

Shows the sequential number assigned to each recording session on the media, distinguishing one session from another rather than numbering individual clips.

### **M** CLIP

Shows the number of media clips recorded.

### **N** MENU

Takes the user to the equipments key settings and adjustments.

### **O** LIVE

Take the user to the LIVE view, which serves as the primary viewfinder screen. It displays the real time image from the sensor, centered on the touchscreen.

### 6.4.3 FPS

#### Custom FPS

1. Press the MENU/BACK button (17).
2. Tap the FPS option on the screen.
3. Tap the ADD option on the screen.
4. Type in the required FPS by tapping the numbers on screen.
5. Tap the SET option to confirm the setting or BACK to return to the previous screen. The set FPS is now part of the pre-set FPS list.

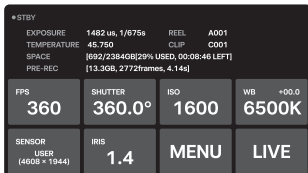
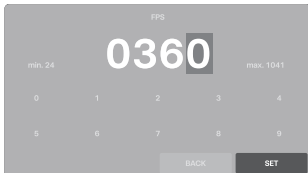
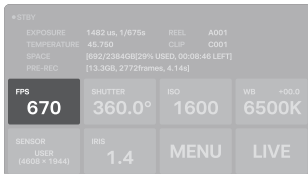

#### Pre-set FPS

1. Instead of tapping the ADD option, scroll up and down to find the required pre-set FPS.
2. Tap the required FPS to select it.
3. Tap the SET option to confirm the selection.

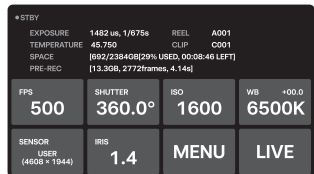
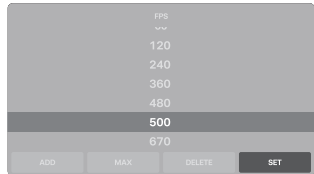

#### Other options

- **MAX**: One-touch selection of the equipment's maximum capable frame rate under current resolution.
- **DELETE**: Double-tap to remove the selected user-added FPS from the list.

## 6.4.4 Shutter speed

### Custom shutter speed

1. Press the MENU/BACK button (17).
2. Tap the SHUTTER option on the screen.
3. Tap the ADD option on the screen.
4. Type in the required shutter speed by tapping the numbers on screen.
5. Tap the SET option to confirm the setting or BACK to return to the previous screen. The set shutter speed is now part of the pre-set shutter speed list.

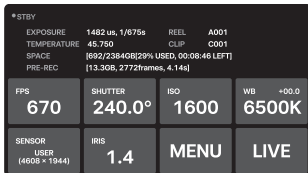
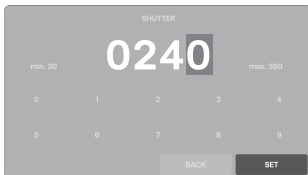
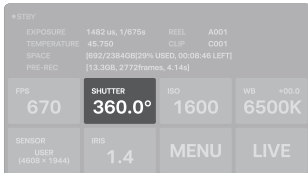

### Pre-set shutter speed

1. Instead of tapping the ADD option, scroll up and down to find the required pre-set shutter speed.
2. Tap the required shutter speed to select it.
3. Tap the SET option to confirm the selection.

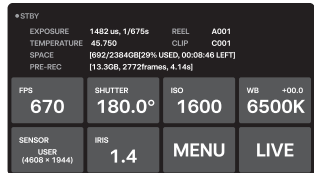

### Other options

- **DELETE:** Double-tap to remove the selected user-added shutter speed from the list.

## 6.4.5 ISO

1. Press the MENU/BACK button (17).
2. Tap the ISO option on the screen.
3. Scroll up and down to find the required pre-set ISO setting.
4. Tap the required ISO setting to select it.
5. Tap the SET option to confirm the selection.

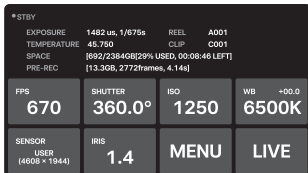
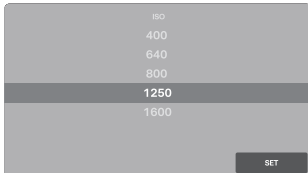
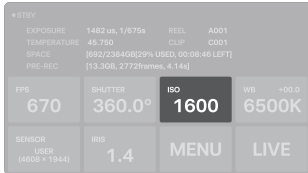

## 6.4.6 White balance (WB)

This interface enables precise White Balance (WB) adjustment by setting the color temperature in Kelvin (K) and the CC (Color Compensating) filter value. The CC value controls the green-magenta tint: +CC adds a green tint, while -CC adds a magenta tint.

### Pre-set WB

1. Press the MENU/BACK button (17).
2. Tap the WB option on the screen.
3. Scroll up and down to find the required pre-set white balance.
4. Tap the required white balance to select it.
5. Tap the SET option to confirm the selection.

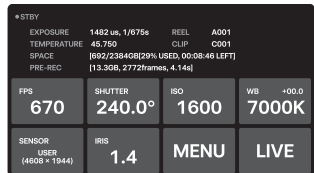
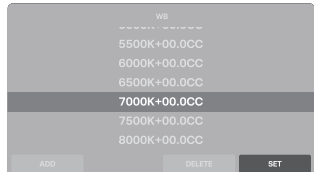
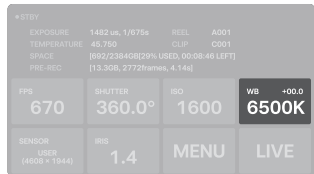

## Custom WB

1. Instead of scrolling, tapping the ADD option.
2. Type in the required white balance by tapping the numbers on screen.
3. Tap the SET option to confirm the setting or BACK to return to the previous screen. The set white balance is now part of the pre-set white balance list.

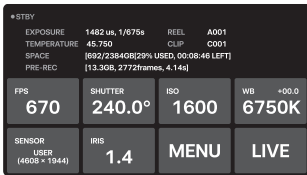
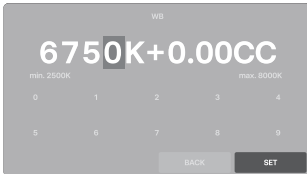
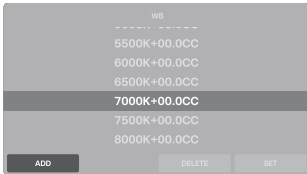

## Other options

- **DELETE:** Double-tap to remove the selected user-added white balance from the list.

## 6.4.7 Resolution

### Pre-set resolution

1. Press the MENU/BACK button (17).
2. Tap the SENSOR option on the screen.
3. Scroll up and down to find the required pre-set sensor resolution.
4. Tap the required sensor resolution to select it.

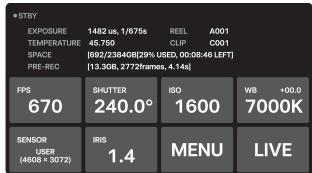
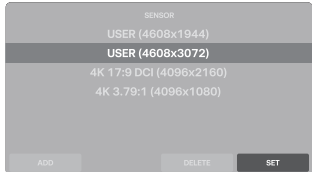
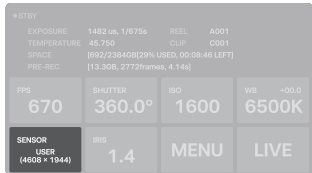

### Custom resolution

1. Instead of scrolling, tapping the ADD option.
2. Type in the required resolution by tapping the numbers on screen.
3. Tap the SET option to confirm the setting or BACK to return to the previous screen. The set resolution is now part of the pre-set resolution list.

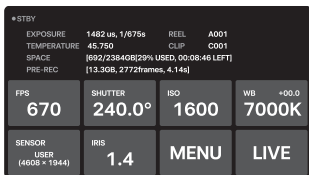
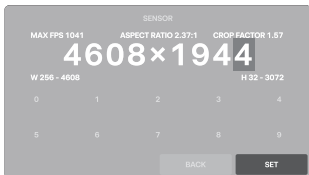
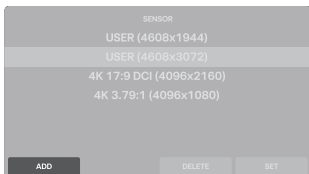

### Other options

- **DELETE:** Double-tap to remove the selected user-added resolution from the list.

### 6.4.8 IRIS

1. Press the MENU/BACK button (17).
2. Tap the IRIS option on the screen.
3. Scroll up and down to find the required pre-set IRIS setting.
4. Tap the required IRIS setting to select it.
5. Tap the SET option to confirm the selection.

The IRIS setting supports common lenses with electronic communication capabilities. Specific compatibility may vary depending on the lens model.

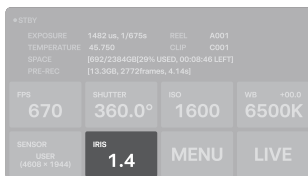

### 6.4.9 MENU

Press the MENU /BACK button (17) or tap the MENU icon on the screen.

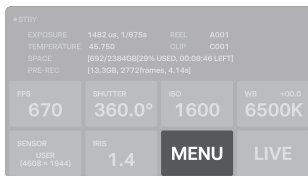

The following sub-menus are available. Select the required sub-menu by tapping:

- Record
- Media
- Monitoring
- User Setting
- System
- Info

## Record

1. Tap Record.
  - **Anamorphic Lens** - Enable or disable anamorphic de-squeeze preview.
  - **Pre-record** - Activate pre-record buffering to capture footage before the record button is pressed (if supported).
  - **Beeper/Tally** - Enable or disable audible beep and tally indicator during recording.
2. Tap SET to save the configuration, otherwise tap or press the BACK button to return to the previous screen.

## Media

1. Tap Media to manage storage options:
  - **Erase Media** - Deletes all files stored on the storage medium.
  - **Media size** - View total capacity and remaining available storage space.
  - **Files** - Review, preview and manage individual recordings on the storage medium.
2. To erase media:
  - Tap the Erase Media → Tap the SET.
  - Follow the message on the screen: Press "ERASE" button for [5s] to erase media.
  - The message "Media erased" will be displayed on the screen.
  - Tap or press the BACK button to return to the previous screen.
3. Tap SET to save the configuration, otherwise tap or press the BACK button to return to the previous screen.

## Monitoring

1. Tap Monitoring
  - a. Tap LCD to adjust:
    - **Brightness** - Adjust screen brightness level.
    - **Flip** - Flip the display orientation.
    - **Info Mode** - Enable or disable on screen information overlay.
  - b. Tap HDMI to configure:
    - **Resolution** - Set HDMI output resolution.
    - **Frame Rate** - Set HDMI output frame rate.
  - c. Tap SET to save the configuration, otherwise tap or press the BACK button to return to the previous screen.

## User Setting

1. Tap User Setting to select user options.
2. Tap the SET to save the configuration, otherwise tap or press the BACK button to return to the previous screen.

## System

1. Tap System to configure system related options.
  - a. **Firmware Update** - Tap Firmware Update to update the equipment firmware using an approved update file.

### NOTICE!

No external drive detected message will appear on the screen if there is no storage medium connected to the device.

- b. **Wi-Fi** – Enable or disable wireless network connectivity.
  - Wi-Fi Mode - Select the operating mode for wireless communication.
  - Wi-Fi Host - Configure or enable the equipment to act as a wireless host (access point) for direct device connection.
- c. **Bluetooth** – Enable or disable Bluetooth® wireless technology connection for compatible devices.
  - Bluetooth Mode - Select the desired Bluetooth operation mode.
  - Device List - View and manage paired or available Bluetooth devices.
- d. **Fan Mode** – Adjust the cooling fan operation to Full, Medium or Low speed.
- e. **Date/Time** – Configure the equipment's internal date and time settings settings.
- f. **Sensor Sync** – Select the trigger mode to synchronize the sensor with external signal generators, supporting various trigger types such as Rising Edge or Falling Edge as Rising Edge or Falling Edge.
- g. **Factory Reset** – Press “RESET” button for [5s] to reset system.

2. Tap SET to save the configuration, otherwise tap or press the BACK button to return to the previous screen.

## Info

1. Tap Info to view the equipment information.
  - a. **Camera Information**

Tap Camera Information to view the options.

    - Software Version
    - OS Version
    - Logic Version
    - Camera SN
    - Sensor SN
    - SoC SN
    - Sensor Data
  - b. **Status**
    - i Tap Status, then tap SET to show the system status information, including operating conditions and connection details.
      - **Sensor Temperature** - Shows the temperature of the equipment sensor.
      - **SoC Temperature** - Shows the temperature of the System-on-Chip (SoC).
      - **Voltage** - Shows the current operating voltage.
      - **Current** - Shows the current draw of the camera.
    - ii Tap SET or press the BACK button to return to the previous screen.
  - c. **Legal & Regulatory**
    - i Tap the Legal & Regulatory option, then tap the SET to view the Legal & Regulatory details. For full legal and regulatory information, refer to chapter 12. Legal.
    - ii Tap or press the BACK button to return to the previous screen.

d. **Lens**

**NOTICE!**

If no lens is detected, error details will be displayed on the screen.

- i Tap the Lens option, then tap the SET to view the Lens details.
- ii Tap or press the BACK button to return to the previous screen.

e. **IMU**

- i Tap IMU to view the options. This page shows the test data output of IMU.
  - ii Tap SET or press the BACK button to return to the previous screen.
2. Tap SET or press the BACK button to return to the previous screen.

## 7. Use

1. Attach a suitable lens, insert the storage media and connect it to a power source.
2. Verify that a charged battery or a suitable external power source is connected.
3. Set the ON/OFF switch (23) to ON to switch the equipment on. The power status indicator (24) lights up. Wait for the equipment start up.
4. Adjust any settings as required.
5. Press the HOME/LIVE button (10) or tap the LIVE on the screen.

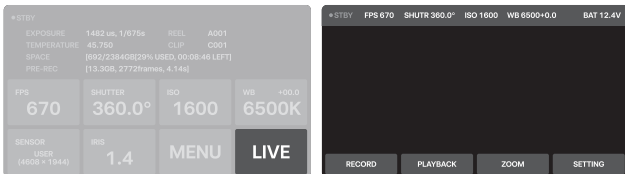

6. The live feed is shown on the screen (16) alongside the current settings and options.
  - **RECORD** - Starts recording video directly from the live feed. Clips are saved to the medium.
  - **PLAYBACK** - Opens the playback interface to review recorded clips. Displaying a still frame from the clip with the live image visible underneath coreference.
  - **ZOOM** - Adjusts magnification of the live feed. Useful for framing, focusing or checking fine details during setup and recording.
  - **SETTING** - Opens the settings menu, allowing configuration of equipment parameters such as exposure, frame rate, shutter, white balance and system preferences.

### 7.1 Recording

To start recording, press/tap any one of the following:

- a. RECORD on the screen.
- b. Screen button (13) directly below RECORD.
- c. Side REC button (25).
- d. Record button (2).

#### NOTICE!

Record button (2) supports assignable full-press and half-press actions. A half-press can trigger pre-record, focus or other user-defined functions, while a full-press starts or stops recording full-press starts or stops recording.

To stop recording:

- Press one of the record buttons or tap STOP on the screen.

## 7.2 Playback

To review recordings, tap **PLAYBACK**. This allows immediate review of the recorded clips.

### PLAYBACK SPEED

Adjusts the playback rate of recorded clips. Users can choose from various speeds (e.g., 1x, 2x, 4x) to review footage at different velocities or frame-accurately.

- **Playback Scrubbing** - The playback progress bar located in the top-right corner of the screen can be dragged to scrub through the clip for quick navigation.
- **USER 1** - Access user-specific settings or presets.
- **LIVE** - Toggles or manages live view settings, including display options.
- **CLIPS** - View recorded clips or access playback options.
- **SAVE** - Save the current image or video to the selected storage medium.
- **PLAY/PAUSE** - Starts or pauses video playback for precise frame review.

## 7.3 Export

### NOTICE!

- The equipment records videos using the proprietary PXBC format and needs to be converted for use with other software.
- Do not remove the storage medium while playback or export operations are in progress. Doing so may corrupt files.

1. After recording is completed, the Pixboom Pro Card (internal SSD module) can be removed from the equipment and connected to a computer using a USB-C cable.
2. The Pixboom Pro Card will appear as a removable storage device formatted with exFAT, containing the recorded PXBC files.
3. Using the Pixboom Cine software compatible with Windows and macOS, these PXBC files can be converted into CinemaDNG image sequences for further post-production workflows. Refer to the Pixboom Cine software instructions for use of the software.

### NOTICE!

A copy of the Pixboom Cine software can be downloaded from: [[www.pixboom.com/downloads](http://www.pixboom.com/downloads)]

## 8. Cleaning and care

### **WARNING! Risk of electric shock!**

- Always switch off the equipment and disconnect it from the power source before any cleaning. This is to reduce the risk of electric shock during cleaning.
- During cleaning, do not immerse the electrical parts of the equipment in water or other liquids. Never hold the equipment under running water.
- Do not spray cleaners directly onto the equipment. Apply cleaning agents to a cloth first.

### **CAUTION! Risk of damage!**

Avoid using harsh or abrasive cleaners, solvents, scouring pads or scrubbers that can damage the surfaces or cause corrosion when cleaning the equipment.

### 8.1 General

- Clean the equipment daily or after use with a soft microfiber cloth, using a mild cleaning solution if necessary, but avoiding solvents and abrasive materials.
- Remove dirt, dust and debris carefully to prevent scratches or damage.
- Keep ventilation inlets and outlets clear of obstructions and dust buildup.

### 8.2 Camera

- Test all buttons, dials and function keys weekly to confirm proper operation.
- Check the HDMI, SDI, USB, EXT and DC IN connectors weekly for dirt or damage and clean gently with a dry cloth if needed.
- Inspect the battery and DC IN connector daily or weekly for wear or corrosion and clean contacts carefully.
- Attach a lens cap when no lens is mounted and use only approved sensor cleaning kits if cleaning is required.
- Clean the lens surface using a blower or soft brush to remove dust, then wipe gently with a soft, lint-free microfiber cloth and an approved lens-cleaning solution. Use light, circular motions starting from the center and moving outward. Avoid scratching the surface, leaving residue or touching optical surfaces with bare fingers.

## 9. Storage

- Thoroughly clean the equipment, remove dirt, debris and any residual substances.
- Make sure all parts are dry to prevent corrosion or damage during storage.
- Make sure the equipment is stored in a secure location, away from unauthorized access and out of reach of children and pets.
- Handle the equipment gently to avoid mechanical stress, impact or vibration.
- Store the equipment only in clean, dry and well-ventilated areas. Avoid damp, humid, excessively hot, dusty areas or areas exposed to direct sunlight.

## 10. Troubleshooting

Follow the instructions provided in this chapter to identify issues and potential solutions. If the issue cannot be resolved independently, seek assistance from an authorized service center or a qualified specialist for further inspection, maintenance and repair work. Alternatively, contact our customer service team for further assistance.

Problem	Cause	Solution
Equipment does not switch on.	• Battery is empty or missing.	• Insert a charged V-Lock battery or connect a suitable external power source.
	• ON/OFF switch (23) not properly pushed to the ON position.	• Slide completely to the ON position.
	• Faulty battery or connector.	• Inspect the contacts. • Try another battery.
No display / live view.	• Screen with touch panel (16) locked.	• Disable screen lock.
	• External monitor connected.	• Check the HDMI and SDI cables, as well as the monitor's power connections.
	• Firmware error.	• Restart the equipment and install the latest firmware update.
Recording does not start.	• No storage medium detected or storage medium improperly installed.	• Properly insert a compatible storage medium.
	• Storage medium full or locked (read-only).	• Replace or format the medium.
	• Front record button (2) / side REC button (25) was mis-configured.	• Check the button assignment. • Make sure that the equipment is ready.

<b>Problem</b>	<b>Cause</b>	<b>Solution</b>
Media errors / corrupted files.	<ul style="list-style-type: none"> <li>Using incompatible storage medium.</li> </ul>	<ul style="list-style-type: none"> <li>Use a compatible storage medium.</li> </ul>
	<ul style="list-style-type: none"> <li>The storage medium was removed.</li> </ul>	<ul style="list-style-type: none"> <li>Wait until the recording finishes before removing.</li> </ul>
	<ul style="list-style-type: none"> <li>Storage medium not formatted.</li> </ul>	<ul style="list-style-type: none"> <li>Format the storage medium before use.</li> </ul>
Overheating / fan running constantly.	<ul style="list-style-type: none"> <li>High ambient temperature or extended recording.</li> </ul>	<ul style="list-style-type: none"> <li>Secure sufficient ventilation, avoid direct sunlight and adjust fan speed.</li> </ul>
Recording LED off	<ul style="list-style-type: none"> <li>Recording not started.</li> </ul>	<ul style="list-style-type: none"> <li>Start recording using screen or buttons.</li> <li>Check storage medium is inserted, recognized and has available storage capacity.</li> </ul>
	<ul style="list-style-type: none"> <li>Storage medium not detected or full.</li> </ul>	<ul style="list-style-type: none"> <li>Check storage medium is correctly installed and has sufficient storage capacity (delete media if required).</li> </ul>
Power status indicator (24) blinking or red.	<ul style="list-style-type: none"> <li>System warning / fault warning / fault detected (such as overheating, media error, connection issue, internal malfunction).</li> </ul>	<ul style="list-style-type: none"> <li>Refer to on-screen message for details and follow corrective steps.</li> </ul>
Power status indicator (24) off.	<ul style="list-style-type: none"> <li>Battery not installed / fully discharged.</li> <li>External/DC power is not connected.</li> </ul>	<ul style="list-style-type: none"> <li>Check the battery is properly installed and sufficiently charged or external power source is connected.</li> </ul>
Wireless / antenna issues.	<ul style="list-style-type: none"> <li>Weak or no signal.</li> </ul>	<ul style="list-style-type: none"> <li>Check the antenna connection and placement.</li> <li>Avoid interference.</li> <li>Verify settings.</li> </ul>
Lens / motor not responding.	<ul style="list-style-type: none"> <li>The motor is not connected or powered.</li> </ul>	<ul style="list-style-type: none"> <li>Verify proper connection and power.</li> </ul>
	<ul style="list-style-type: none"> <li>Motor gear touched during operation.</li> </ul>	<ul style="list-style-type: none"> <li>Keep fingers, hair, loose clothing and accessories away from moving parts such as lens motors.</li> </ul>

# 11. Technical data

## 11.1 Camera

---

Model	Spark P101
-------	------------

---

### Input

---

Adapter	15–24 V $\overline{=}$ (+/-10 %), 4.8 A
---------	---

---

Battery	<ul style="list-style-type: none"><li>• Battery type: V-Lock battery</li><li>• Battery voltage range: 10 V – 30 V Li-on</li><li>• Power priority: DC-IN overrides the battery when both are connected</li></ul>
---------	---

---

### Environmental

---

Operating temperature	32°F to 104°F (0°C to 40°C)
-----------------------	-----------------------------

---

Relative humidity	0 % to 85 % non-condensing
-------------------	----------------------------

---

Storage temperature	-4°F to 140°F (-25°C to 60°C)
---------------------	-------------------------------

---

### General

---

Weight (body only)	approx. 2.42 lb (1.1kg)
--------------------	-------------------------

---

Material	Aluminum alloy
----------	----------------

---

Dimensions (excluding the mount adapter)	4.25 × 4.33 × 5.12 in (108 × 110 × 130 mm) (H × W × L, largest fixed dimensions)
--	---

---

Media type	Removable Pixboom Pro Card
------------	----------------------------

---

Media type export speed	20 Gbps (USB 3.2 Gen 2 × 2)
-------------------------	-----------------------------

---

Media export method	Export via Type-C without requiring any card reader
---------------------	---

---

Screen	3.5 in 6.22 M-dot, 16:9 screen
--------	--------------------------------

---

Battery attachment	Integrated V-Lock battery interface optimized for V-Lock battery
--------------------	--

---

### Features

---

Remote control	<ul style="list-style-type: none"><li>• Wi-Fi Local area network for camera control</li><li>• UART control via 9-pin EXT port</li></ul>
----------------	---

---

Wi-Fi/Bluetooth frequency band	<ul style="list-style-type: none"> <li>• 2400-2483.5 MHz</li> <li>• 5150-5350 MHz</li> <li>• 5725-5850 MHz</li> </ul>
Max. RF power transmit	<p>≤ 20 dBm EIRP in the 2400-2483.5 MHz band</p> <ol style="list-style-type: none"> <li>1. ≤ 20 dBm EIRP in the 5150-5350 MHz band</li> <li>2. ≤ 33 dBm EIRP in the 5725-5850 MHz band (or ≤ 20/23 dBm EIRP where TPC is not supported)</li> </ol>
Monitor outputs	<ul style="list-style-type: none"> <li>• Integrated touchscreen LCD with preview and camera control</li> <li>• 12 G SDI for 4k output</li> <li>• HDMI 2.0 for 4k output</li> </ul>
Additional I/O	<ul style="list-style-type: none"> <li>• Genlock through 9-Pin EXT Port</li> <li>• Linear Timecode (LTC) through 9-Pin EXT Port</li> <li>• GPIO through 9-Pin EXT Port</li> </ul>
Software	Pixboom Cine (RAW processing software for Windows and macOS)
<b>Standards</b>	
Safety	UL 62368-1
Safety (CE RED)	<ul style="list-style-type: none"> <li>• IEC 62368-1: 2018</li> <li>• EN 62368-1</li> </ul>
Cyber Security (CE RED)	<ul style="list-style-type: none"> <li>• EN 18031-1</li> <li>• EN 18031-2</li> </ul>
EMC + RF (CE RED)	<ul style="list-style-type: none"> <li>• EN 62311</li> <li>• EN 62479</li> <li>• EN 62368-1</li> <li>• EN 301 489-1</li> <li>• EN 301 489-3</li> <li>• EN 301 489-17</li> <li>• EN 55032</li> <li>• EN 55035</li> <li>• EN 300 893</li> <li>• EN 300 328</li> </ul>
FCC ID	2AL6KBL-M8852BU1

---

## Sensors type

---

Sensor readout	Global Shutter
Sensor type	14.2 MP super 35 mm global shutter CMOS
Sensor size	4608 × 3072   25.34 mm × 16.90 mm (diagonal: 30.46 mm)
Dynamic range	13 stops

---

## Mount adapter type

---

Type	Interchangeable locking mount (E/EF/PL)
Electronic communication	Support

---

## Recording

---

Max data rates	Up to 10 GB/s using Pixboom Pro Card
Pixboom RAW solution max. frame rates	<ul style="list-style-type: none"><li>• 670 fps at 4.6K Open Gate 3:2 (4608 × 3072)</li><li>• 887 fps at 4K 16:9 (4096 × 2304)</li><li>• 1171 fps at 4k 2.37:1 (4096 × 1728)</li><li>• 1724 fps at 2k 16:9 (2048 × 1152)</li><li>• 2182 fps at 2k 2.37:1 (2048 × 864)</li></ul>
Supported formats	<ul style="list-style-type: none"><li>• 4.6K (3:2 OpenGate, 16:9, 2:1, 2.37:1, 4:1)</li><li>• 4K formats</li><li>• 2K formats</li><li>• Custom user-defined resolutions</li></ul>
Max. resolution	4608 × 3072 (4.6K OpenGate)
Max. frame rate	Up to 3625 fps (depending on selected resolution)
Exposure control	Shutter angle adjustment
ISO	<ul style="list-style-type: none"><li>• 400</li><li>• 640</li><li>• 800</li><li>• 1250</li><li>• 1600</li></ul>
White balance	Adjustable Kelvin (K) and CC (Green/Magenta offset)

---

Video outputs	<ul style="list-style-type: none"> <li>• SDI: 12 G-SDI output</li> <li>• HDMI: HDMI 2.0 output</li> <li>• Sync Port: Genlock / Timecode support via extension port</li> </ul>
Mechanical mounting	<ul style="list-style-type: none"> <li>• 1/4-20</li> <li>• 3/8-16</li> <li>• Multiple M4 mounting points</li> </ul>
Cooling system	Active cooling with intake and exhaust ventilation
Recording media	Dedicated Pixboom Pro Card

## Imaging system specifications

Mode	Resolution		Max FPS	Image area (mm)		Image circle (mm)
4.6K 3:2 OpenGate	4608	3072	670	25.34	16.90	30.46
4.6K 16:9	4608	2592	781	25.34	14.26	29.08
4.6K 2:1	4608	2304	887	25.34	12.67	28.34
4.6K 2.37:1	4608	1944	1025	25.34	10.69	27.51
4.6K 4:1	4608	1152	1724	25.34	6.34	26.12
4K 16:9	4608	2304	887	22.53	12.67	25.85
4K 2:1	4608	2048	994	22.53	11.26	25.19
4K 2.37:1	4608	1728	1171	22.53	9.50	24.45
4K 4:1	4608	1024	1926	22.53	5.63	23.22
2K 16:9	4608	1152	1724	11.26	6.34	12.92
2K 2.37:1	4608	864	2182	11.26	4.75	12.23
2K 4:1	4608	512	3625	11.26	2.82	11.61

## 11.2 AC Power Adapter

Model	J655-1504800DMI
Input	100-240 V $\sim$ , 50/60 Hz, 1.7 A
Output	15.0 V $\equiv$ , 4.8 A, 72.0 W

## 12. Legal

### REGULATORY INFORMATION

Regulatory markings and certification information for this product can be viewed in the system menu.

Path: MENU>Info>Legal and Regulatory

### 12.1 United States of America

#### 12.1.1 FCC Compliance Statement



This device complies with Part 15 of the FCC Rules. Operation is subject to the following two conditions: (1) this device may not cause harmful interference and (2) this device must accept any interference received, including interference that may cause undesired operation.

**Warning:** Changes or modifications not expressly approved by the party responsible for compliance could void the user's authority to operate the equipment.

**Note:** This equipment has been tested and found to comply with the limits for a Class digital device, pursuant to Part 15 of the FCC Rules. These limits are designed to provide reasonable protection against harmful interference in a residential installation. This equipment generates, uses and can radiate radio frequency energy and, if not installed and used in accordance with the instructions, may cause harmful interference to radio communications. However, there is no guarantee that interference will not occur in a particular installation.

If this equipment does cause harmful interference to radio or television reception, which can be determined by turning the equipment off and on, the user is encouraged to try to correct the interference by one or more of the following measures:

- Reorient or relocate the receiving antenna.
- Increase the separation between the equipment and receiver.
- Connect the equipment into an outlet on a circuit different from that to which the receiver is connected.
- Consult the dealer or an experienced radio/TV technician for help.
- This equipment complies with FCC radiation exposure limits set forth for an uncontrolled environment.
- This equipment should be installed and operated with a minimum distance of 20 cm between the radiator and the user's body.
- Tap MENU>Info>Legal and Regulatory to enter scanner information page, to view the FCC IC ID and regulatory information.

## 12.1.2 U.S. Contact Information

PIXBOOM  
FABRIS MICH SERVICE LLC 2  
5680 Greenwood Plaza Blvd, Suite 120 #1001  
Greenwood Village, CO 80111  
United States  
+1 929-774-2907  
support@pixboom.com

## 12.2 European Union

### 12.2.1 RF Exposure Information (EU)

- This equipment complies with EU radiation exposure limits set forth for an uncontrolled environment.
- This equipment should be installed and operated with a minimum distance of 20 cm between the radiator and the user's body.

#### EUROPEAN UNION COMPLIANCE STATEMENTS



The CE Mark is a Directive conformity mark of the European Community (EC).

This radio equipment operates in the following frequency bands:  
2400–2483.5 MHz, 5150–5350 MHz and 5725–5850 MHz.

The maximum radio-frequency power transmitted in the frequency bands is:

- ≤ 20 dBm EIRP in the 2400–2483.5 MHz band;
- ≤ 20 dBm EIRP in the 5150–5350 MHz band;
- ≤ 33 dBm EIRP in the 5725–5850 MHz band  
(or ≤ 20 / 23 dBm EIRP where TPC is not supported).

The firmware version is indicated on the first page of this document. User-upgradeable firmware does not affect compliance with the essential requirements.

The product is marketed with interchangeable accessories including SSD accessory and mount adaptor accessories. These accessories are user-replaceable and do not affect compliance with the essential requirements of the applicable CE directives.

Hereby, Pixboom declares that the radio equipment type described in this document (Pixboom Spark, model P101) is in compliance with Directive 2014/53/EU. The full text of the EU declaration of conformity is available at the following internet address:  
[[www.pixboom.com/security](http://www.pixboom.com/security)]

To maintain compliance with the RF exposure requirement, a separation distance of 20 cm between the device and the human should be maintained.

## 12.2.2 Privacy Notice

This device may capture or process images, video recordings or device identifiers.

Users are responsible for ensuring that the use of this device complies with applicable data protection laws, including the General Data Protection Regulation (GDPR).

When recording individuals, appropriate legal permissions may be required.

## 12.2.3 Data Privacy and GDPR Compliance Notice

This equipment can capture and store video or image data. If used in the European Union, the General Data Protection Regulation (GDPR) (EU) 22016/679 applies to any processing of personal data, including identifiable images or recordings.

As the user, you must comply with GDPR requirements, including:

- **Lawful use:** Do not record areas where people expect privacy (e.g., restrooms, private homes) without clear legal basis or consent.
- **Legitimate interest:** Only record if necessary for a specific, lawful purpose that does not override individual rights.
- **Transparency:** Place visible signs before monitored areas. Inform individuals about the purpose of recording and how their data is used.
- **Data minimization:** Record only what is needed. Avoid excessive or unnecessary footage.
- **Storage limitation:** Delete recordings when no longer needed. Atypical retention period is 24 to 72 hours unless legally required otherwise.
- **Security:** Protect stored data from unauthorized access, loss or misuse.
- **Respect rights:** Individuals may request access, correction or deletion of their personal data.
- **Disposal:** Before selling or disposing of the equipment, remove and securely wipe any memory cards or storage devices.
- **DPIA:** If you monitor public spaces or use biometric features (e.g., facial recognition), conduct a Data Protection Impact Assessment.

Misuse of this equipment may violate privacy laws. The manufacturer is not responsible for non-compliant use.

## 12.3 Australian



AUSTRALIAN COMPLIANCE STATEMENTS

## **12.4 General**

### **12.4.1 Disclaimer**

This document is intended solely as an informational guide for the Pixboom Spark. The specifications, features, performance characteristics and design elements described herein may be updated, revised or modified at any time without prior notice as part of ongoing equipment development.

While every effort has been made to ensure the accuracy of the information provided, Pixboom does not guarantee that this manual is free from errors or omissions. The content of this publication does not constitute a binding agreement, warranty or contractual obligation of any kind.

Pixboom shall not be held responsible for any loss or damage, whether direct, indirect, incidental or consequential, arising from the use or misuse of the equipment, failure to follow operating instructions or unauthorized alterations.

It is the responsibility of the user to ensure that the operation of the equipment complies with all applicable laws, regulations and safety requirements in their region. No portion of this manual may be reproduced, stored in a retrieval system or transmitted in any form or by any means without prior written authorization from Pixboom.

For the most recent updates, technical information and official documentation, please visit the official Pixboom website [[www.pixboom.com](http://www.pixboom.com)]

### **12.4.2 Copyright**

©[2026] Pixboom Innovations. All rights reserved. The Pixboom Spark P101, including its design, documentation and associated materials, is the intellectual property of Pixboom Innovations. This equipment and its content are protected under international copyright and trademark laws.

No portion of the Pixboom Spark P101 materials may be copied, modified, translated or distributed in any form without prior written consent from FPXBOOM Innovations.

Unauthorized use, reproduction or adaptation is strictly prohibited and may result in civil and criminal penalties.

PIXBOOM, the Pixboom Spark P101 name and associated logos are registered trademarks of Pixboom Innovations.

### 12.4.3 Trademarks

PIXBOOM, Pixboom Spark P101 and the distinctive PIXBOOM logos are exclusive trademarks of Pixboom Innovations. These marks represent the originality, quality and innovation of Pixboom products.

All other product names, company names or logos mentioned in Pixboom Spark P101 documentation remain the property of their respective owners. References are made solely for identification and do not imply endorsement or affiliation.

Any unauthorized use, imitation or modification of PIXBOOM trademarks is strictly prohibited and will be enforced under applicable trademark and intellectual property laws.

#### Bluetooth®

The Bluetooth® word mark and Logos are registered trademarks owned by Bluetooth SIG, Inc. and any use of such marks by Pixboom is under license. Other trademarks and trade names are those of their respective owners.



#### HDMI

The Adopted Trademarks HDMI, HDMI High-Definition Multimedia Interface and the HDMI Logo are trademarks or registered trademarks of HDMI Licensing Administrator, Inc. in the United States and other countries.



#### DNG

DNG is a trademark or registered trademark of Adobe Systems Incorporated in the United States and other countries.

#### Windows

Windows is a trademark of Microsoft Corporation in the United States and/or other countries.

#### exFAT

exFAT is a trademark of Microsoft Corporation in the United States and/or other countries.

#### macOS

macOS is a trademark of Apple Inc. in the United States and other countries.

#### QR Code

QR Code is a registered trademark of DENSO WAVE INCORPORATED in Japan and other countries.

All other trademarks mentioned in this manual are the trademarks or registered trademarks of their respective owners.

## 12.5 EU Packaging and Packaging Waste Regulation (PPWR) Compliance

This product and its packaging are designed to comply with Regulation (EU) 2025/40 on Packaging and Packaging Waste (PPWR). We confirm that as of the date of application (12 August 2026), the packaging meets the following criteria:

**Substance Restrictions:** Complies with Article 5 regarding restrictions on hazardous substances, including lead, cadmium, mercury, hexavalent chromium and PFAS thresholds.

**Recyclability:** Designed for material recycling in accordance with Article 6.

**Minimization:** Optimized to reduce weight and volume to the minimum necessary for functionality (Article 10).

**Labeling:** Currently marked with material identification codes; will transition to harmonized EU pictograms by the August 2028 deadline.

### **Consumer Information:**

- Please separate packaging components by material type.
- Dispose of packaging in accordance with local municipal recycling guidelines.

### **Our Commitment to Sustainability:**

Pixboom supports the EU's goals to reduce packaging waste by 5% by 2030, 10% by 2035 and 15% by 2040 through optimized design and material efficiency.

## 13. Disposal

### 13.1 European Union

#### 13.1.1 Equipment disposal



The Waste Electrical and Electronic Equipment (WEEE) directive aims to minimize the impact of electrical and electronic goods on the environment and human health, by increasing re-use and recycling and by reducing the amount of electrical and electronic waste going to landfills. The symbol on this equipment and its packaging signifies that this equipment must be disposed separately from ordinary household waste at the end of its life. Be aware that this is the responsibility of the owner to dispose of electrical and electronic waste at recycling centers in order to conserve natural resources. Each country has its collection centers for electrical and electronic waste. For information about recycling drop off areas, contact the local electrical and electronic equipment waste management authority, the local city office or the household waste disposal service.

#### 13.1.2 Packaging/packing materials disposal

Sorting and disposing of packaging materials correctly is essential for environmentally friendly waste management. The packaging is designed to protect the equipment during transit and is made of materials that can be recycled.

- Dispose of cardboard and paperboard packaging by submitting them to the recycled paper service or waste paper collection. Check with local recycling facilities for specific guidelines on recycling cardboard and paperboard.
- Dispose of wrapping materials, inserts, straps and other plastic packaging by checking with local recycling facilities for specific guidelines on recycling or waste disposal methods. Follow their instructions to ensure proper disposal and promote environmental sustainability.

## 14. Warranty

Pixboom stands behind the quality of its products. This device is warranted against manufacturing defects in materials and expertise under normal and intended use for a period of 2 years from the original date of delivery, unless otherwise required by applicable local laws.

During the warranty period, Pixboom will, at its discretion, repair or replace any defective product or part at no charge, provided that the product has been used in accordance with the instructions in this manual.

### 14.1 Warranty coverage

Pixboom stands behind the quality of its products. Unless otherwise stated on the product page, all products sold by Pixboom come with a limited warranty covering manufacturing defects for a period of 2 years from the date of delivery.

This warranty does not cover damage resulting from misuse, neglect, unauthorized modification, or normal wear and tear. To make a warranty claim, contact us via the contact form at [www.pixboom.com] with your order number, a description of the defect, and supporting photographs. If the claim is approved, we will, at our sole discretion, repair, replace, or refund the product. This warranty is in addition to, and does not affect, your statutory rights.

### 14.2 Warranty conditions

Warranty service will be provided only when:

- The product was purchased from the Pixboom official website, an authorized reseller or distributor.
- A valid proof of purchase is presented.
- The product has been installed, operated and maintained in accordance with the instructions provided in the user manual.

### 14.3 Exclusions

- Damage resulting from misuse, improper installation, negligence, accident or unauthorized modification.
- Damage caused by power surges, improper voltage, environment exposure or natural disasters.
- Normal cosmetic wear and tear that does not affect product functionality.
- Accessories, consumables or parts subject to regular replacement.

### 14.4 Limitation of liability

Pixboom shall not be liable for any indirect, incidental or consequential damages arising from the use of this product.

For assistance or warranty claims, contact your local authorized dealer or Pixboom customer support.

## **15. EU declaration of conformity**

Hereby, EU Consulted Srls, Via Varesina 55, Milano 20156, Italy, declares that the radio equipment type Spark P101 is in compliance with Directive 2014/53/EU.

The full text of the EU declaration of conformity is available at the following internet address:  
[[www.pixboom.com/security](http://www.pixboom.com/security)]

## **16. UK declaration of conformity**

Hereby, OVERSEA WALKERS LIMITED, 7 Bell Yard, London, WC2A 2JR, UK, declares that the radio equipment type Spark P101 is in compliance with The Radio Equipment Regulation 2017.

The full text of the UK declaration of conformity is available at the following address:  
[[www.pixboom.com/security](http://www.pixboom.com/security)]

The Statement of Compliance for this product is available at the following address:  
[[www.pixboom.com/security](http://www.pixboom.com/security)]

# PIXBOOM

---

Pixboom Technology Co.,Ltd  
Room 403, 4th Floor, South End of Building 101, Building 7, Yard 11, Xingke,  
Yanqi Economic Development Zone, Huairou District, Beijing, China.

---

Importer for UK: ACUVIS Systems Limited  
Address: Unit 82A James Carter Road, Mildenhall, Bury St Edmunds, IP28 7DE, UK

---

The Pixboom logo is a trademark of Pixboom Technology Co., Ltd  
Copyright © 2026 Pixboom Technology Co., Ltd. All Rights Reserved.  
Made in China

---

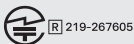

Contains FCC ID: 2AL6KBL-M8852BU1